



MG RELAY CO.,LTD.
www.mgrelay.com

MR20

功率继电器
Power relay



特性 Features :

25A切换大容量 (25A switching capacity)

完整的附加功能(指示旗/LED指示燈/手动测试旋鈕) 可依需求搭配組合
Complete additional function indicator flag / LED indicator / Manual Test Knob can be combined as required

具有多种触点组合 (With multiple contact combinations)

镀金触点型Gold plated contact type

透明防尘罩、多种安装方式Transparent dust cover and various installation method

环保产品RoHS和REACH

性能参数 Coil parameter

触点型式Contact type	一组转换/二组转换/三组转换/1组常开/2组常开/3组常开 /1组常闭/2组常闭/3组常闭(1C/2C/3C/1A/2A/3A/1B/2B/3B)	
接触电阻 Contact Resistance	≤ 50mΩ	
触点材料 Contact Material	AgCdO银镉 /AgSnO银锡	
阻性负载 Resistive load	1C/2C/ 2A/2B	13A , 28VDC 20A , 15VDC 25A , 300VAC , resistive 20A , 277VAC , ballast 5A , 600VAC , resistive 1HP , 120VAC 1-1/2HP , 208/240VAC 1HP , 480/600VAC 660VA , 120VAC 915VA , 208VAC 960VA , 240VAC 765 , 480/600VAC B600 A@120VAC
	3C/3A/3B	13A , 28VDC 15A , 28VDC (N.O.only) 20A , 15VDC 20A , 150VAC , resistive 15A , 250VAC , resistive 20A , 150VAC , ballast 20A , 277VAC , ballast 10A , 300VAC , resistive 1/2HP , 120/208/240VAC 1HP , 240VAC 3/4HP , 120VAC 470VA , 120/240VAC 445VA , 208VAC B300
马达负载 Motor load	1/3hp@120VAC 1/2hp@240VAC	

最大切换电压 Max. Switching Voltage	28VDC,600VAC	
最大切换电流 Max. Switching Current	25A	
最大切换功率 Max. Switching Power	1C/2C:364W,7500VA 3C:420W,3750VA	
绝缘电阻 Insulation resistance	1000MΩ /500VDC	
介质耐压 Dielectric strength	同极触点间 Between open contact	1000VAC,1Min
	异极触点间 Between different pole	1500VAC,1Min
	线圈触点间 Between contact and coil	1500VAC,1Min
动作时间 Operate time	AC≤30ms,DC≤20ms	
释放时间 Release time	AC≤25ms,DC≤15ms	
冲击稳定性 Stability of shock resistance	98m/s ²	
冲击强度 Shock strength	980m/s ²	
环境温度 Ambient temperature	-\$-30^{\circ}\text{C} \sim +50^{\circ}\text{C}\$ (AC) -\$-30^{\circ}\text{C} \sim +65^{\circ}\text{C}\$ (DC) (无结冰、无结露 No ICE, no dew)	
环境湿度 Ambient Humidity	5%RH ~ 85%RH	
振动 Vibration	10Hz ~ 55Hz, Double amplitude 1.0mm	
机械寿命 Mechanical life	1000,0000 ops	
电气寿命 Electrical life	10,0000 ops	
额定线圈功率 Rated coil power	直流 (DC) 1.2-1.5W 交流 (AC) 3.0-3.4VA	
重量 Weight	≤88g	
体积Volume	35mm×38mm ×47.5mm	
配套插座或连接器 Matching socket or connector	S2 terminal : BTA3-11A , BTA3-11AN	
产品应用领域Product application area	机床、工业控制设备、电梯电控设备、安防控制领域、电源控制等 Machine tool、Industrial Control Equipment、Elevator control equipment、Field of security control、Power Control	
产品应用场合Applications	电源、焊接设备、自动贩卖机、通信设备、防灾设备、测量仪器、娱乐机器、Power supply、Welding equipment、Vending machine、Communication equipment、Disaster Prevention equipment、Measuring Instrument、Entertainment Machine	
同行参考Peer Reference	泰科TYCO : KUMP系列 (KUMP series) 施耐德Schneider : 389系列(389 series)	

线圈规格表 Coil Versions (环境温度+ 23℃ The ambient temperature is 23℃)

额定电压 (V) Rated voltage		工作电压 (V) Operate voltage	释放电压 (V) Release voltage	最大电压(V) MAX.voltage	线圈电阻(Ω) Coil sistance
DC 1C/2C	6VDC	≤80%	≥10%	110%	29.5±10%
	12VDC				120±10%
	24VDC				472±10%
	48VDC				1800±10%
	110VDC				10000±10%
	125VDC				10000±10%
DC 3C	6VDC				21.3±10%
	12VDC				85±10%
	24VDC				340±10%
	48VDC				1360±10%
	110VDC				8500±10%
	125VDC				8500±10%
AC 1C/2C	6VAC	≤85%	≥30%	110%	4.43±10%
	12VAC				17.7±10%
	24VAC				1580±10%
	110VAC				1630±10%
	120VAC				5850±10%
	220VAC/230VAC				5850±10%
	240VAC				7200±10%
AC 3C	6VAC				3.8±10%
	12VAC				15±10%
	24VAC				60±10%
	48VAC				240±10%
	120VAC				1300±10%
	240VAC				4300±10%

备注：最大电压是指继电器在短时间内能够承受的最大电压值。

Note: The maximum voltage is the maximum that the relay can withstand in a short period of time.

订货标记示例 Order mark example

编号说明	MR20	-2C	()	-S2	-C	MLB	-120VAC
系列Series MR20							
触点形式Contact form 1C/2C/3C/1A/2A/3A/1B/2B/3B							
触点负载Contact rating 空白Blank: AC:25A DC:13A							
引出端形式Terminal style 空白Blank : 标准型 Standard type S:6.3*0.8mm / S1:4.8*0.8mm/ S2:4.8*0.5mm/ P1:1.2*0.8mm / P2:1.2*0.8mm/ p3:1.2*0.8mm							
外壳样式Cover style C:标准型普通外壳Standard case C1:侧面法兰外壳Side flange housing C3:顶端法兰外壳Top flange housing C4:卡轨外壳Rail housing							
选配Options M: 手动按钮 Manual Push Button, DC 蓝色 Blue, AC 红色 Red L: 单向红色 Single-Polar Red LED(for AC), 双向绿色Bi-Polar GreenLED (for DC) B:磁铁灭弧 (仅对2C直流负载) Arc Suppression by Magnet (only for 2C DC load)							
线圈电压Coil voltage A: AC交流 DC: DC直流							

外形尺寸图 Dimension drawing

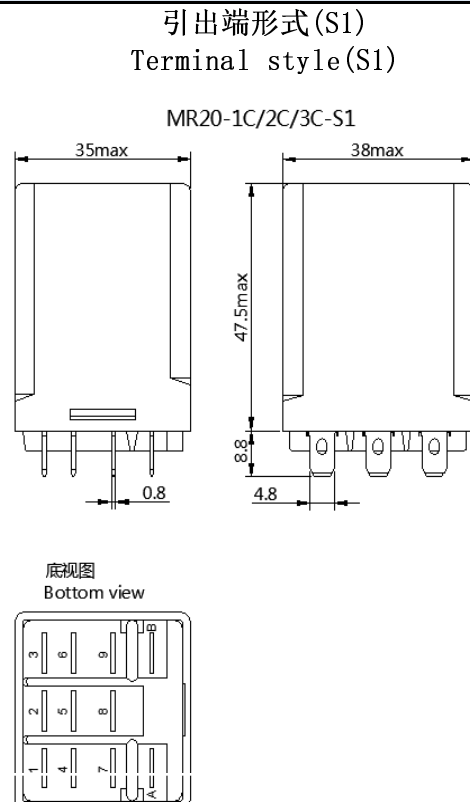
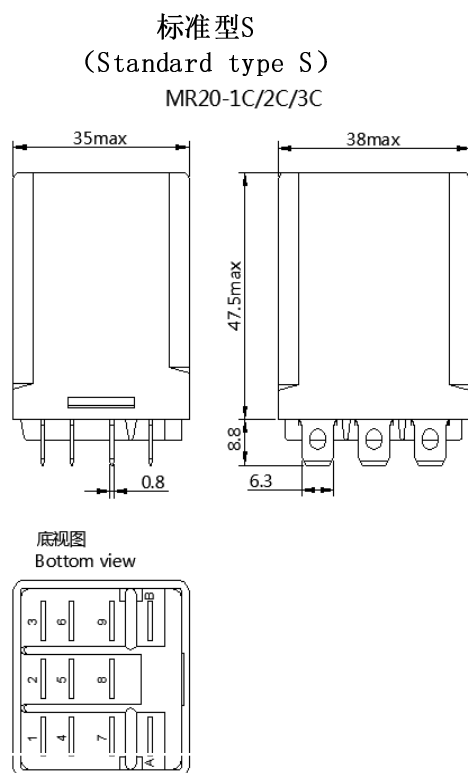

引出端形式(S2)
Terminal style(S2)
MR20-1C/2C/3C-S2

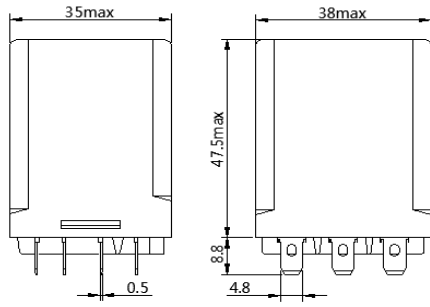

底视图
Bottom view

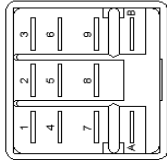

引出端形式：印制电路板式(P1)
Terminal form: PCB(P1)
MR20-1C/2C/3C-P1

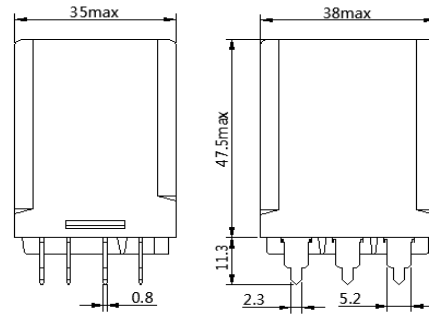

底视图
Bottom view

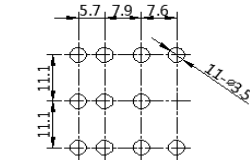
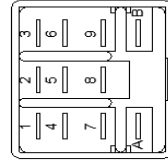

引出端形式：印制电路板式(P2)
Terminal form: PCB(P2)
MR20-1C/2C/3C-P2

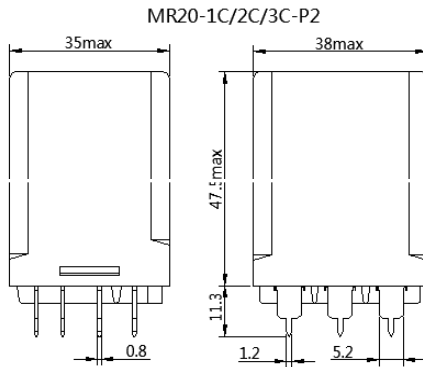

底视图
Bottom view

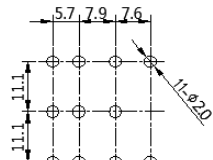
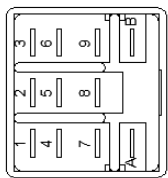

引出端形式：印制电路板式(P3)
Terminal form: PCB(P3)
MR20-1C/2C/3C-P3

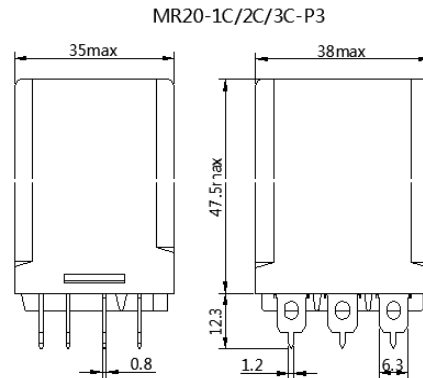

底视图
Bottom view

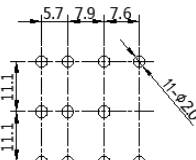
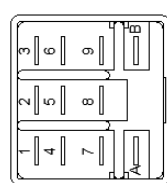

侧面法兰外壳(C1)
Side flange cover(C1)
MR20-1C/2C/3C-C1

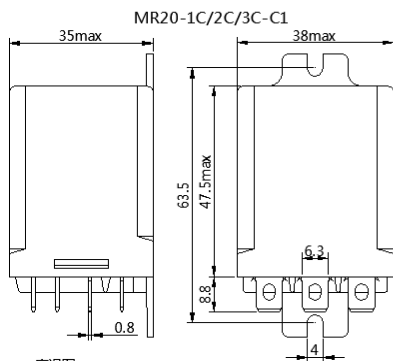

底视图
Bottom view

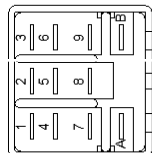

顶端法兰外壳(C3)
Top flange cover(C3)
MR20-1C/2C/3C-C3

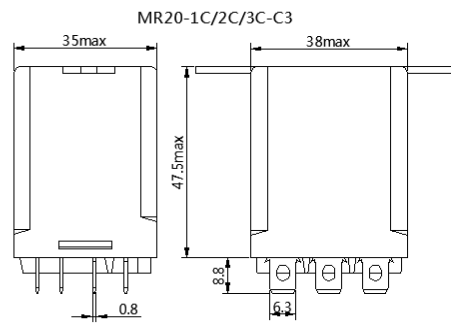

底视图
Bottom view

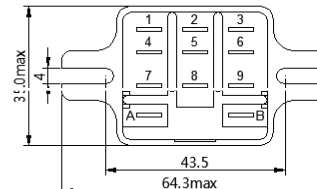

卡轨外壳 (C4)
Din rail cover (C4)

MR20-1C/2C/3C-C4

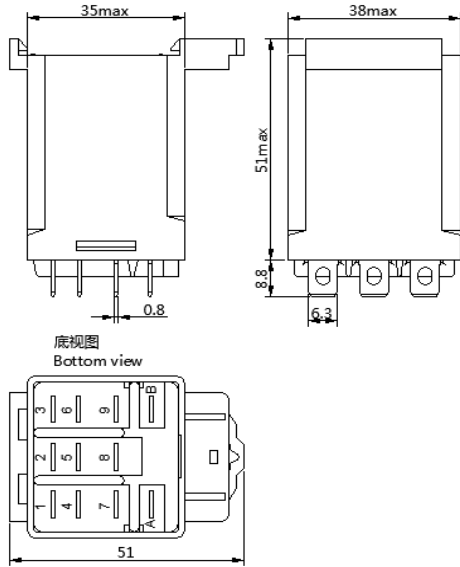

手动测试按钮 (M4)
Manual test button (M)

MR20-1C/2C/3C-M

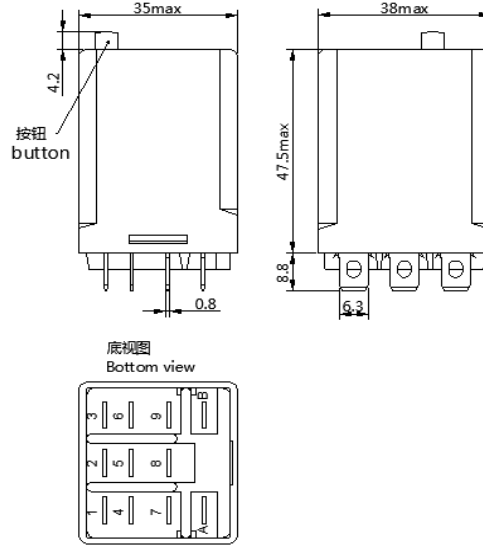

带灭弧磁铁 (B)
Blowout magnet (B)

MR20-2C-B

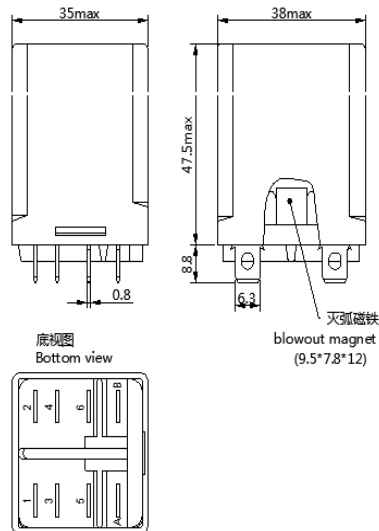

内部接线图 Wiring diagrams

MR20-1C

直流、交流线圈,无LED
DC, AC coil, Without LED
MR20-1C

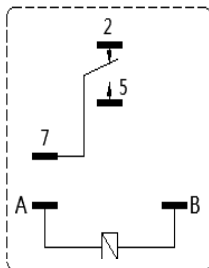

直流线圈,双向LED
DC coil, Bi-Polar LED
MR20-1C-L-□□VDC

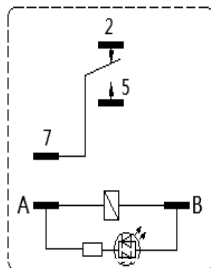

交流线圈, 220~240VAC除外
单向LED
AC coil, Except for 220~
240VAC, Single-Polar LED
MR20-1C-L-□□VAC

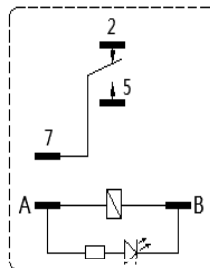

220VAC~240VAC线圈
单向LED+二极管
220VAC~240VAC coil
Single-polar LED+diode
MR20-1C-L-220VAC~240VAC

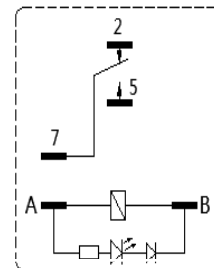

MR20-2C

直流、交流线圈,无LED
DC, AC coil, Without LED
MR20-2C

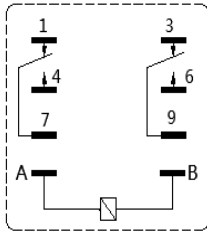

直流线圈,双向LED
DC coil, Bi-Polar LED
MR20-2C-L-□□VDC

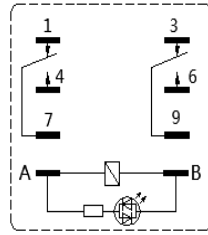

交流线圈, 220~240VAC除外
单向LED
AC coil, Except for 220~240VAC, Single-Polar LED
MR20-2C-L-□□VAC

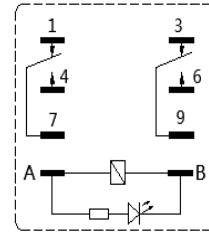

220VAC~240VAC线圈
单向LED+二极管
220VAC~240VAC coil
Single-polar LED+diode
MR20-2C-L-220VAC~240VAC

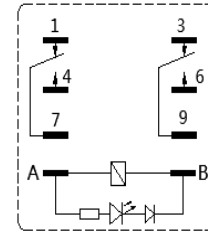

MR20-3C

直流、交流线圈,无LED
DC, AC coil, Without LED
MR20-3C

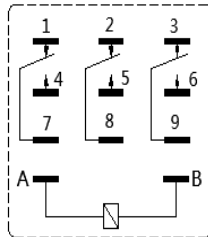

直流线圈,双向LED
DC coil, Bi-Polar LED
MR20-3C-L-□□VDC

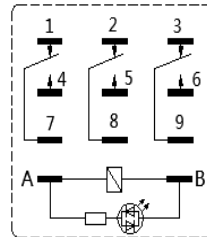

交流线圈, 220~240VAC除外
单向LED
AC coil, Except for 220~240VAC, Single-Polar LED
MR20-3C-L-□□VAC

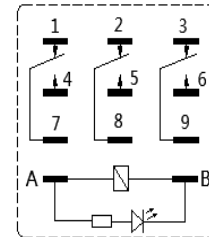

220VAC~240VAC线圈
单向LED+二极管
220VAC~240VAC coil
Single-polar LED+diode
MR20-3C-L-220VAC~240VAC

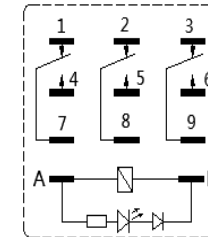

注: 1, 对于DC规格, 请在确认线圈极性后正确接线。

For DC specifications, please connect correctly after confirming coil-level performance.

2, 动作指示灯显示线圈通电情况, 并非根据触点动作进行显示

the action indicator shows the current status of the coil, not according to the action of the contact

继电器配套插座: Relay socket (另售Resel I)

插座型號 Socket type	連接繼電器型號 Type of connecting relay	型狀 SHAPE	安裝方式 Installation mode	材質 Material Quality
BTA3-11A	MR20 (S2)		1. 兩側螺絲孔安裝; 2. 導軌安裝	PA

插座性能Socket performance

插座型號 Socket type	負載電流Load current	負載電壓 Load voltage	介質耐壓Dielectric strength		外連接導線External connecting conductor		螺釘扭矩Screw Torque	防護等級 Protection level
			線圈及觸點間 Between Coil and contact	觸點間 Contact Point	AWG	mm ²		
			V/S	V/S				
BTA3-11A	12A	240VAC	1500	1500	20-16	0.5-1.5	0.7Nm	/

注意事項Points to note

关于使用: About using

对于动作指示灯内置型, 请在确认线圈极性后正确接线 (DC操作)

For Action Indicator built-in type, please connect correctly after confirming coil polarity (DC operation)

关于安装: About installation

无安装方向限制, 请尽量避免接点移动方向易受振动、冲击的安装方式

No installation direction limit, please try to avoid contact moving direction susceptible to vibration, impact of the installation

关于继电器的更换: ON REPLACEMENT OF RELAYS:

因维护等原因更换继电器时, 为防止继电器的误动作及触电事故, 请务必切断负载侧和继电器线圈的电源。

When changing the relay for maintenance and other reasons, please cut off the power supply of the load side and the relay coil in order to prevent misoperation and electric shock of the relay.