

# >>>小型大功率继电器(BLY5)



BLY5-2C



BLY5-1C



BLY5-3C



BLY5-4C



## 产品特点

- >20A切换大容量
- >多种接点形式：1C(1组转换) (2C)2组转换, 3C(3组转换) (4C)4组转换
- >内置机械指示显示继电器动作状态
- >LED指示灯：显示线圈“接通”或都“断开”状态
- >旋转按钮：线圈不通电情况下，允许手动操作旋转按钮，适用于调试人员手动测试电路

## 型号说明

编号说明	<b>BLY5</b>	<b>-2C</b>	<b>5</b>	<b>-S</b>	<b>-C</b>	<b>M4LW</b>	<b>-24VDC</b>
系列: BLY5							
触点形式 1C:SPDT 2C:DPDT 3C:3PDT 4C:4PDT							
触点负载 空白Blank: 10A 12:12A 15:15A 20:20A							
引出端形式 S:标准型插座插入式 P:PCB印制板式							
外壳样式 C:标准型普通外壳							

### 选配

- W:无内置机械指示标志 (未选:表示有内置机械指示标志)
- M:手动测试按钮 (未选:表示无手动测试按钮)
- 4:有自锁功能的旋转按钮 (未选:表示无自锁功能的旋转按钮)
- L:LED指示灯 (未选:表示无LED指示灯)
- 注:AC指示灯为红色 DC指示灯为绿色 (更直观区分AC和DC)

### 线圈电压Coil voltage

- A: AC交流 DC: DC直流 (6-110VDC 6-240VAC)

## >产品性能

型式		1C	2C	3C	4C
触点	负载	阻性		10A@28VDC/240VA 12A@28VDC/277VAC 15A@120VAC	
		马达		1/3Hp,120VAC/ 1/2Hp,240VAC 1/2Hp,240VAC 3/4Hp,240VAC	
切换功率		560W, 5540VA		336W/3324VA	
接触电阻 (初始)		≤50mΩ			
接点材料		10A:AgNi 银镍 12A/15A/20A:AgSnO2 银锡			
电气寿命		10,000 ops			
机械寿命		1000,000 ops			
吸合电压 (23℃)		DC:≤75%(额定电压), AC: ≤80% 50/60HZ(额定电压)			
释放电压 (23℃)		DC:≥10%(额定电压), AC: ≥30% 50/60HZ(额定电压)			
最大电压 (23℃)		110% (额定电压)			
绝缘电阻 Insulation resistance		500MΩ @500VDC			
线圈功率	DC(W)	0.89-1.1W			
	AC(VA)	1.2VA			
吸合时间(额定电压)		≤20ms			
释放时间(额定电压)		≤15ms			
初始耐压	同极触点之间	1000VAC,1Min (漏电流1mA)			
	异极触点之间	1500VAC,1Min (漏电流1mA)			
	线圈与触点间	1500VAC,1Min (漏电流1mA)			
环境温度		-25℃~+55℃ (AC/DC) (无结冰、无结露)			
环境湿度		5%RH~85%RH			
大气压力		86-106KPa			
冲击稳定性		98m/s2			
耐冲击强度		980m/s2			
耐振动		10Hz~55Hz, Double amplitude 1.0mm			
安装方式		插入式&PCB式可选			
体积		27.5×14×35.5 mm	28×21.5×35mm	28×30.8×35mm	28×40.8×35mm
重量		约24g	约37g	约58g	约78g

## >线圈规格表 (环境温度+ 23℃)

额定电压 (V)		工作电压 (V)	释放电压 (V)	最大电压(V)	线圈电阻(Ω) ±10%			
					1C	2C	3C	4C
DC	6VDC	≤75%	≥10%	110%	47	40	25	24
	12VDC				188	160	100	96
	24VDC				750	650	400	388
	48VDC				2600	2600	1600	1550
	110VDC				15125	11000	8500	7340
AC	6VAC	≤80%	≥30%	110%	18.8	9.5	6	5.4
	12VAC				76.8	46	25.3	21.2
	24VAC				300	180	103	84.5
	48VAC				1280	770	460	340
	110VAC				6950	3830	220	1800
	120VAC				7680	4430	2770	2220
	220VAC/230VAC				15000	15000	10800	8520
240VAC	15720	157000	12100	9120				

备注：最大电压是指继电器在短时间内能够承受的最大电压值。

## >外形图尺寸 (mm)

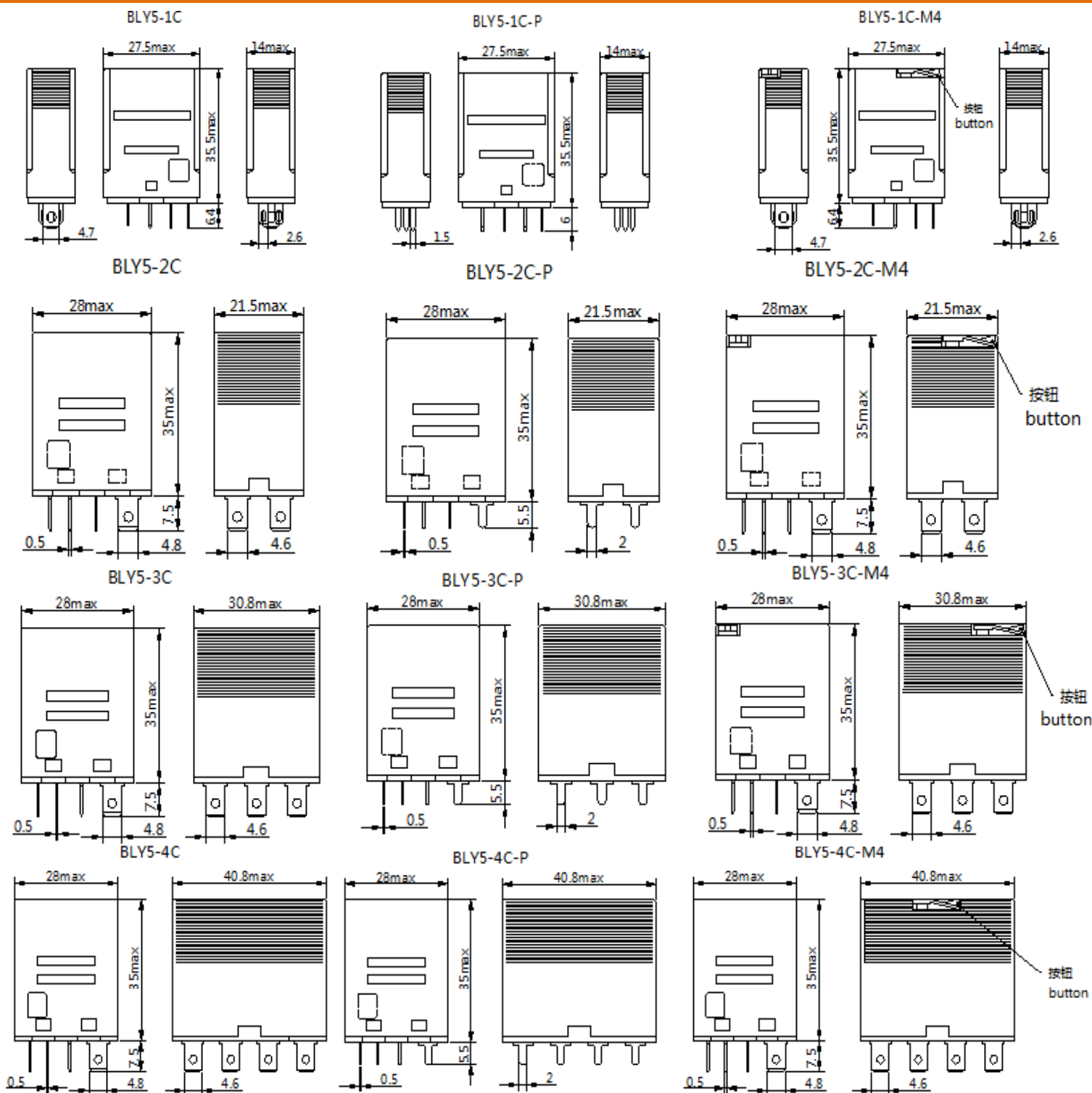

BLY5-1C

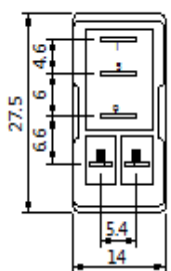

BLY5-2C

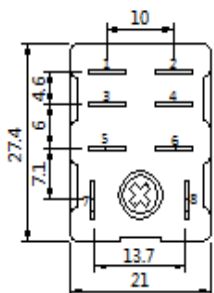

BLY5-3C

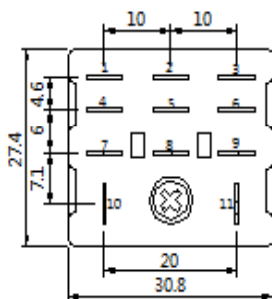

BLY5-4C

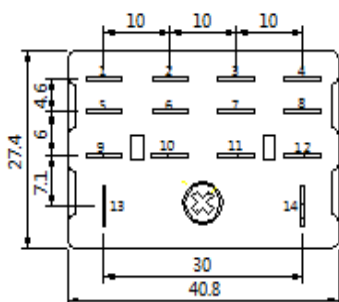

1C DC

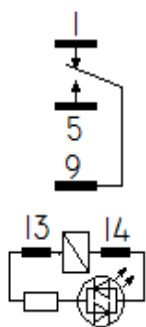

1C AC

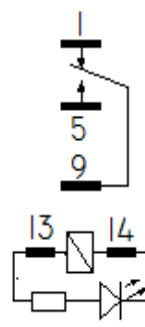

2C DC

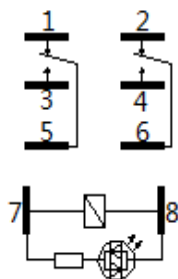

2C AC

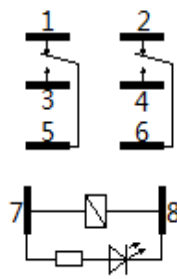

3C DC

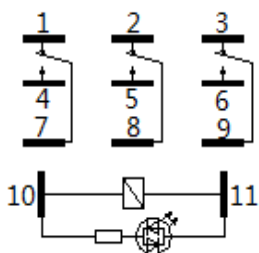

3C AC

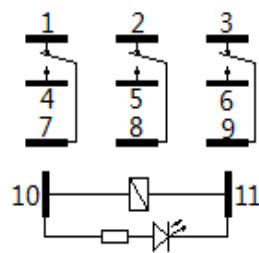

4C DC

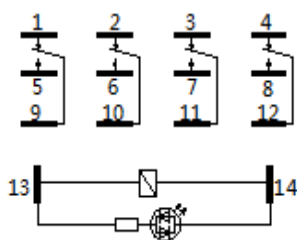

4C AC

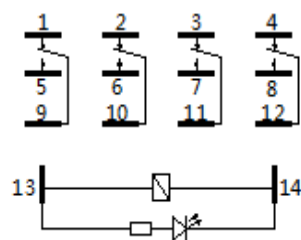

>>>其它可选插座 (相关参数见BMY5插座说明)



PTF-05AN



PTF-08A/B



PTF-08



PTF-11A/B



PTF-14A/B